

CHAPTER 24

Installing and Adjusting

1. Installing

Before installing a burner, it is assumed that *inspection* and *preparation* have been made as instructed in Chapter 23. The inspection includes the calculations for radiation and checked against the house loss and the size of nozzle and burner determined.

In addition to this, the size and location of the tank and thermostat should be discussed with the owner and adjusted to his satisfaction.

In the opinion of the author, the location of the thermostat is very important as the whole operation of the system depends upon the "orders" given by the thermostat. That is to say, the thermostat is the pulse which gives life to the system."

Of course, the size and location of the tank should also be discussed with the owner and adjusted to his satisfaction—informing him that the standard size of tank is 275 gallons.

Tools.—The following is a complete list of tools required for the proper installation and service of a conversion burner.

Laborer's Tools.— 2 long handled shovels, round nose; 1 pick axe; 2 bull points; 2—12 quart pails; 1 sledge; 1 mash hammer; 1— $\frac{1}{2}$ in. star drill; 1 large star drill; 1 $\frac{3}{8}$ in. star drill; 1 fire shovel; 1 crow bar; 1 pinch bar; 1 wire brush; 1 large square canvas.

Pipe Fitter's Tools.— 1 pipe vise—up to 2 $\frac{1}{2}$ ins. capacity; 1 pipe vise stand; 1—24 in. pipe wrench; 1—18 in. pipe wrench; 1—10 in.

pipe wrench; 1 oil can; 1 flanging tool for copper tube; 1 vacuum pressure pump, hand type; 1—3 roll pipe cutter; 1 hack saw and blades; 1 pair of tin snips; 1 can graphite paste; stocks and dies suitable for pipe $\frac{1}{8}$ in. to 2 ins.; reamers suitable for pipe $\frac{1}{8}$ in. to 2 ins.

Miscellaneous Tools— 1 power drill $\frac{1}{2}$ in. capacity; 1 bolt cutter $\frac{3}{8}$ in. capacity; 1 set socket wrenches, offset type (removeable); 1—6 in. crescent wrench; 1—8 in. crescent wrench; 1—12 in. monkey wrench; 1—20 in. monkey wrench; 1 heavy screw driver; 1 machinist hammer; 1 soft hammer; 1 center punch; 1 pressure gauge; 1 flame mirror; 1 instalometer.

Electrician's Tools— 1 small alcohol torch; 1 pair gas pliers; 1 pair of electrician's pliers; 1 pair of cutting pliers; 1 fish wire; 1 flash light; 1 double socket; 1 conduit bending tool; 2 extension cords and guards; screw drivers of various sizes; soldering material.

Mason's Tools— 1 plastering trowel; 1 mason trowel; 1 brick hammer; 1 broad chisel; 1—6 ft. rule; 1—12 in. metal frame level; 1 stone hammer; 1 small hoe.

Carpenter's Tools— 1—20 in. course cut off saw; 1 key hole saw; 1 claw hammer; 1—10 in. file; 1— $\frac{1}{2}$ in. wood chisel; 1—2 in. wood chisel; 1 bell hanger's bit, 24 in. brace and bits.

Materials— A standard average conversion oil burner installation with an inside tank will require the following materials: 1 oil burner; 1 nozzle; 1 master control relay; 1 limit control; 1 thermostat; 1 draught regulator.

Tank— 1—275 gallon fuel tank with legs; 1 fuel gauge.

Electrical— 1 square D switch; 50 ft. Bx. cable, 2 wire; 8 straight Bx. connectors; 10 ft.— $\frac{1}{2}$ in. conduit; 3 $\frac{1}{2}$ in. locknuts; 1 junction box; 50 ft.—3 wire thermo. cable; 2 fuses; 10 ft. Bx. cable, 3 wire; 50 ft. No. 14 wire; pipe straps and Bx. staples; thermostat wire staples.

Piping, fill line— 10 ft.—2 in. pipe; 4—2 in. elbows; 2—2 in. st. elbows; 1—2 in. x 3 in. nipples; 2—2 in. x 6 in. nipple; 1—2 in. cap.

Piping, vent line— 15 ft.—1 $\frac{1}{4}$ in. pipe; 2—1 $\frac{1}{4}$ in. elbows; 1—1 $\frac{1}{4}$ in. x 6 in. nipple; 1—1 $\frac{1}{4}$ in. vent cap; 2—1 $\frac{1}{4}$ in. st. elbows.

Tank to Burner— 1— $\frac{3}{8}$ in. valve; 1— $\frac{1}{2}$ in. x $\frac{3}{8}$ in. bushing; 25 ft.— $\frac{3}{8}$ in. copper tubing; 2— $\frac{3}{8}$ in. flare nuts; 1— $\frac{3}{8}$ in. adaptor; 1— $\frac{3}{8}$ in. C to P elbow; 1— $\frac{3}{8}$ in. x 3 in. nipple.

Fire Box— 55 fire bricks; 10 split fire bricks; loose insulating materials; 50 lb. asbestos cement; 50 lb. hi-temp. cement; 20 lb. Portland cement; 5 lb. furnace cement.

Cleaning and Preparation—Although the author in Chapter 23 gave some instructions on preparation, he is going into the subject here more in detail. The following procedure should be taken in installing the unit:

Clean the Chimney— 1. Clean the base of the flue.

2. Clean the flue throughout if any soot be deposited so as to obstruct the cross sectional area.

3. If the chimney be defective in any way, the owner should be notified so that he can have it repaired.

Clean the Boiler—1. Remove the ash pit door and the grates, and if necessary, the ash pit door frame.

2. Clean the soot, ashes and scale from all the flue passes and the inner surfaces of the boiler.

3. Clean out the ash pit.

4. Seal the leaks around the door frame and between the sections with furnace cement.

5. Check the fit of all the fire and cleanout doors and file them if necessary to make them fit tight.

Smoke Pipe—1. Unless the smoke pipe be in good, sound condition, replace it.

2. Do not use 90° ells — use 45's whenever possible.

3. Seal all the joints in the smoke pipe.

4. Check the draught. There is nothing more important in the operation of an oil burner than that it has a proper draught. The chimney should be of sufficient cross section area, not less than an 8 in. x 8 in. chimney with no other outlets into it and should have a draught at the base of it when cold of approximately .06 of an inch, as measured

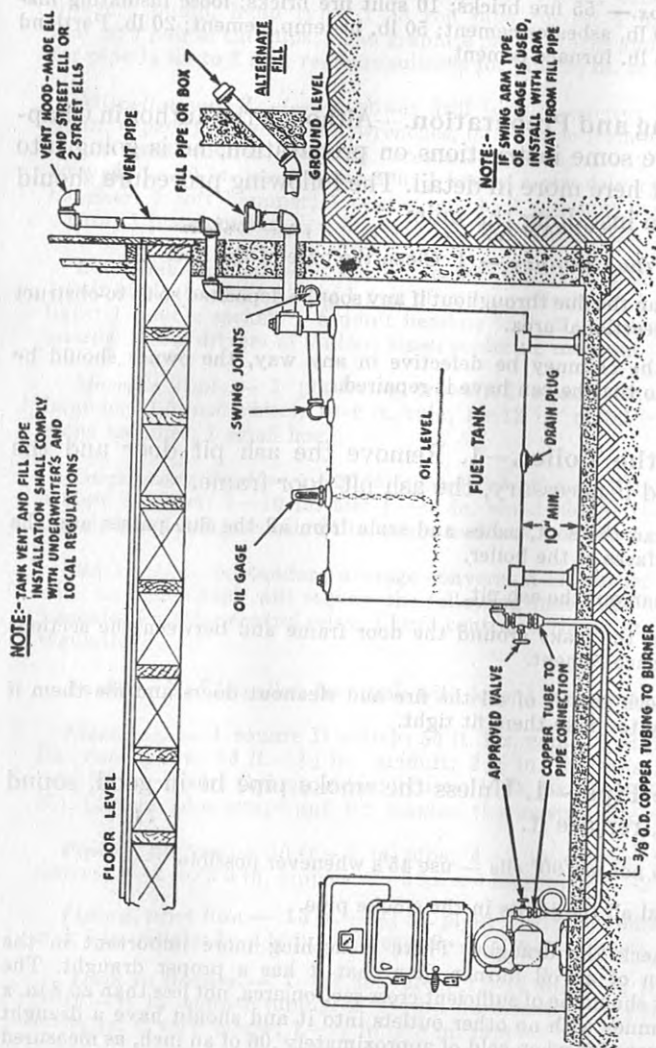

FIG. 1.—Simple basement single pipe system. Instructions for Models MF and MS. Use copper tubing for all oil lines. For threads, use a good oil proof joint compound. Use only one oil line (inlet) on all basement tanks when connection is made to outlet at bottom of oil tank. Bottom of tank should be above center line of pump. Use two oil lines (inlet and return) in all underground tanks. Burners come from factory with pump arranged for one pipe hook-up. When connecting more

with a draught gauge. *The burner must have a positive draught at all times.*

5. Smoke pipe should pitch upward throughout its length.
6. Dampers should be removed.

Draught.—1. Draught is absolutely necessary to the proper operation of a domestic oil burner;

2. Pulsating of flames, vibration of boilers and concussion from unsteady combustion are, with very few exceptions, caused by insufficient draught to clear the fire box of the products of combustion.

3. Draught is a property and function of either boiler or chimney construction or both.

4. So-called draught regulators do not create draught. Their sole purpose is to steady the draught, usually by reducing it.

5. If there be not enough draught to clear the fire box, there are only three remedies. *a*, provide quicker draught by raising chimney, etc. *b*, a larger flue area; *c*, reducing the flame size, keeping in mind that the boiler must receive sufficient heat.

6. Do not expect the burner fan to force a draught condition, as it will only lead to bad operation.

7. Draught regulators should be set to maintain approximately .02 in. draught over fire when burner is operating.

Tanks and Piping.—Inside tanks should be placed at least 7 feet away from the burner in a place where it is convenient

Fig. 1—Text continued.

than one burner to a single tank, separate inlet lines should be run to each burner. Return lines may be manifolded. Whenever a new burner is installed to replace an old one, a new inlet line must be installed, or else the old one must be thoroughly tested for leaks, to avoid serious operating difficulties in the future. Never fasten oil lines along basement ceiling. 1. Erect tank on an iron stand or iron pipe legs with floor flanges about 10 inches high. Never rest tank on the basement floor. 2. Find a suitable spot and cut a single or two holes in foundation or framework through which fill and vent pipes pass. 3. Install the fill and vent pipes. Make sure all joints are tight and that they pitch to drain to the tank, with no traps. 4. Neatly plug hole in foundation or wall with suitable water proof material. 5. Screw a $\frac{1}{4}$ in. nipple and the required shut-off valve into the lower outlet of the tank. 6. Screw another $\frac{1}{4}$ in. nipple and a valve into the pump inlet opening. 7. Run a piece of heavy walled soft copper tubing between the valves. Provide a loop or a swing joint at the burner connection. These instructions also relate to fig. 2.

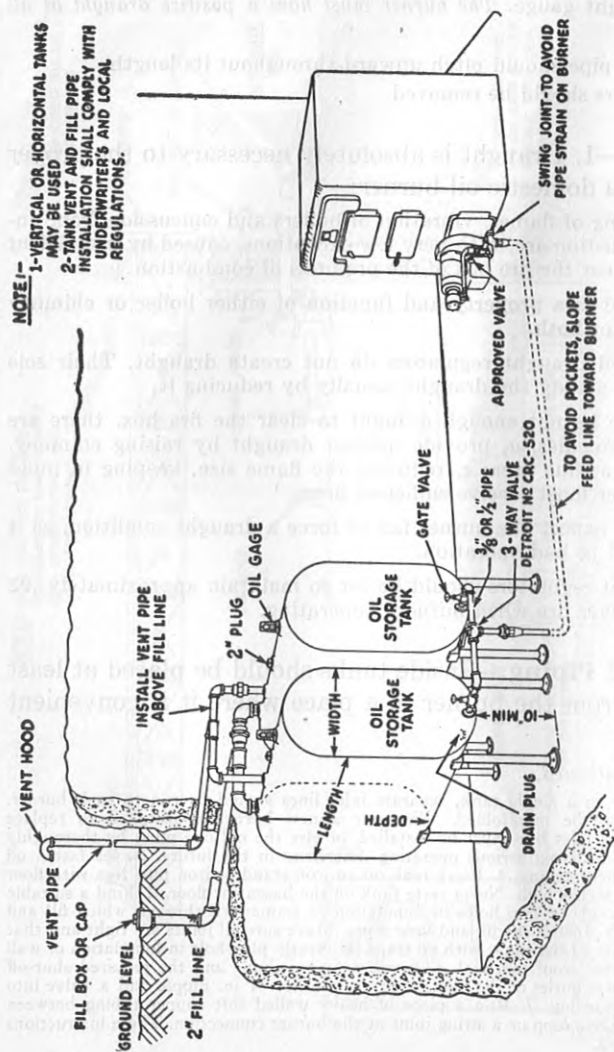

FIG. 2—Dual basement installation — not permitted in all localities.

to reach them with a fill and vent. Location should be determined upon and be satisfactory to the owner before the tank is put in. All inside tanks should be provided with legs or with standards. Tanks should meet the Underwriter's requirements and

should not exceed 275 gallons for individual tanks. Tanks larger than 275 must be handled in accordance with governing regulations.

Intake Line.—The intake (or alleged "suction") line may be of black (not galvanized) steel or of copper pipe. It should be at least $\frac{3}{8}$ inch inside diameter in size. If copper tubing be used, it should be of the soft, heavy wall type with approved and satisfactory fittings. Use of light wall pipe will lead to excessive tank hum.

For runs of over 50 feet a larger pipe should be used. All joints should be made absolutely air tight as this is the most critical part of good burner operation, that of having a tight intake line. Test the intake line with a vacuum gauge.

There are two standard methods of intake line arrangements:

1. **Single pipe system;** where a recirculating path is provided within the pump or at the pump. In this connection no return line is used and the bottom of the tank should not be below the level of the pump and should preferably be a few inches above the level of the pump.

2. **Double pipe system;** where a return line is run to the tank. The two pipe system must be used whenever the bottom of the tank is below the center line of the pump. Wherever possible the intake line should be buried in the cellar floor after it has been proven to be air tight. However, in cases of waterproof floors, intake line should be carried close to a wall on the top of the floor and covered with a protecting layer of concrete. No intake or return pipes should be run overhead on the ceilings. A shut-off valve should be used at the tank.

All outside tanks should have return line connections if lower than the pump.

Two or more burners should never be connected to the same intake line. Each burner must have a separate intake line of its own. All piping should be run in such a manner as to avoid strain, and in the case of copper tubing, a loop is sometimes used to prevent this.

Fill and Vent.—Fill line should be of best grade black pipe unless local regulations require that the material be galvanized.

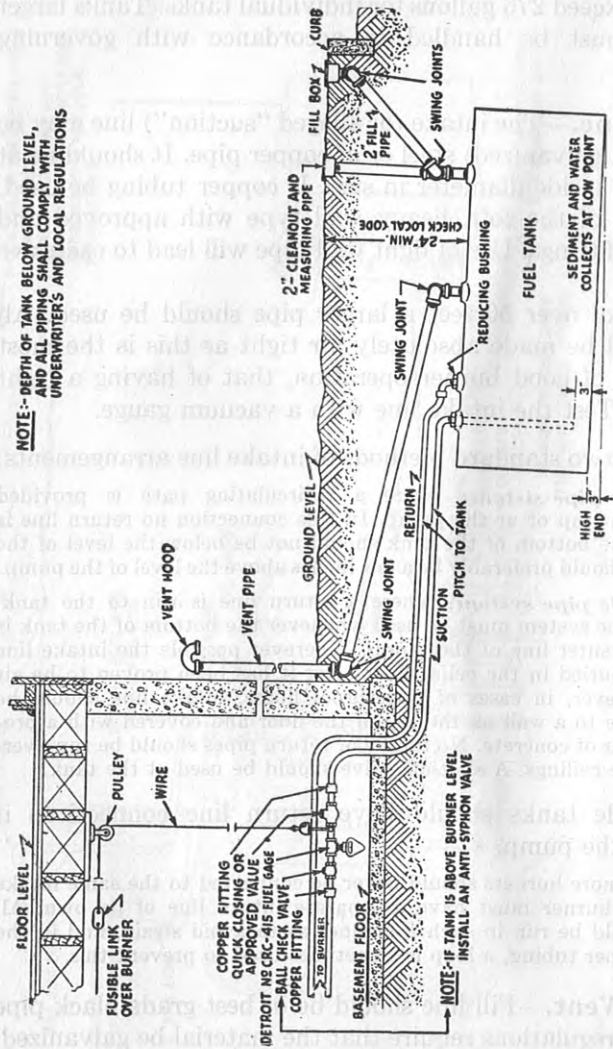

NOTE--DEPTH OF TANK BELOW GROUND LEVEL, AND ALL PIPING SHALL COMPLY WITH UNDERWRITERS AND LOCAL REGULATIONS

Fig. 3—Underground tank installation, tank below burner level. 1. Insert by-pass Plug B into pump as per instructions attached to pump. 2. Locate the tank at least 4 feet from the foundation, with the inlet lines as short as possible, and to be convenient for filling. 3. The depth shall be such that the top of the tank is below the front line. In general, this is a minimum of two feet, unless local regulation requires more. 4. Install fill, vent, clean-out or measuring pipe and oil gauge, as shown in fig. 3. 5. Inlet line shall be one piece from inside the wall and reach within 3 inches of bottom of tank. Use $\frac{1}{2}$ in. O.D. for runs about 30 feet from tank to wall, $\frac{3}{4}$ in. O.D. for longer runs. Pitch line from wall back to tank.

It should be two inches in diameter and should have a weather-proof closure at the outside.

Good threads and tight joints are imperative. Compounds such as Permatex, Keypaste and many others are suitable for use on the joints. Do not use red or white lead or litharge.

The vent pipe shall be of $1\frac{1}{4}$ in. black steel material unless galvanized is specified by local requirements, and should extend at least three feet above the grade line on the outside of the house.

Consult local regulations covering the installation of such items. It should be equipped with an inverted weatherproof vent which has been screened so that foreign material cannot be dropped into the pipe.

Both vent pipe and fuel pipe should slope upward from the tank with no definite horizontals and with no traps.

Combustion Chamber.—The very highest grade of fire brick should be used. For the floor of the fire box, $1\frac{1}{4}$ in. split brick, laid dry, are generally used and the sides, front and rear wall a standard $8 \times 4\frac{1}{2} \times 2\frac{1}{2}$ in. fire brick are employed. The brick should be laid in a very good quality of refractory cement, mixed very thin, and the bricks simply dipped in this very thin mixture and laid in place so that the layer of cement between the bricks is as thin as possible.

Use a high temperature cement that will not blister. The boxes should be sized and the nozzle heights above the floor of the box maintained.

Fig. 3—Text continued.

6. To inside end attach an approved shut-off valve. 7. Into the valve screw a short nipple. 8. Screw a tee with a $\frac{1}{2}$ inch side outlet to the nipple, pointing down. 9. To this side outlet, secure fuel storage gauge. 10. Next install a horizontal ball check valve (or an anti-syphon valve if required). 11. Run a one piece copper tube inlet line from the check valve to the required valve at the burner. This tubing may be one size smaller than the outside line. Provide an expansion loop at the burner connection. 12. Return line must be used. It must be same or one size larger than the inlet line.

The walls of the combustion chamber should usually be twice the height of the nozzle above the floor and must in any event be high enough to protect the water leg of the boiler.

Lay out a loose fire box on the floor outside the boiler with fire bricks to see how the bricks are going to fit. After fire box is completed within the boiler, fill in and line the outer walls of the fire box with insulating material. Such materials are mineral wool, Zonolite and several other insulating materials.

Preformed Chambers.—Many fire boxes are now on the market which are made of preformed brick and they work out very well. They are usually of a refractory material so shaped as to fit together and form an oval shaped box and the filler is used behind them exactly as in the case of the plain fire brick. The sizing of the fire boxes used should closely follow the recommendation by the manufacturer. Be sure proper nozzle heights are maintained.

Shape of the Chamber.—There is some slight advantage in rounding the corners on the back of the combustion chamber, but the advantage is so slight that it hardly pays for the extra labor involved. Therefore a chamber with square corners is recommended except on the most particular jobs.

When the combustion chamber required will not occupy the entire fire box area of the boiler, the chamber should be built in the front section, and behind the walls should be filled in with broken brick or coarse cinders.

Do not use fine ashes or sand for the filling because it becomes damp due to the boiler "sweating" in summer and will swell or entrap moisture which may result in damaged combustion chamber walls.

Chambers for Large Boilers.—In large boilers where the combustion chamber does not occupy the entire fire box, efficiency can be gained by corbelling out the three or four top courses of brick in the rear wall, each course about $\frac{3}{4}$ in. beyond the one below, this making an overhanging wall.

If a boiler be a poor steamer, or be overloaded, even though it be small, efficiency can often be gained by using this type of construction. Cases are known where boilers could never develop an ounce of pressure until this type of rear wall was built.

Combustion Chamber Defects.—When poor results are obtained due to a faulty combustion chamber, it is much oftener the case that the chamber is too large, rather than too small. This applies particularly to its length. A short chamber insures an intimate agitation and mixture of the air and oil spray and resulting good combustion. A chamber that is too long will not serve this purpose and at times the flame will not even sustain itself.

When in doubt as to the length of the chamber, choose the shorter one.

Round Boiler Defects.—Round cast iron boilers show a very poor efficiency when operated with oil burners, unless there be *four* or *five* pancake sections. A boiler of this type, according to Branford, provided with but two pancake sections, will probably not give more than 40% efficiency with oil, because the boiler offers then so little heating surface and flue travel. The gas velocities will be so high that the gases of combustion will not be able to transfer their heat thoroughly before passing into the smoke pipe.

Selecting the Nozzle to Use.—There are various methods used by oil burner engineers for determining the firing rate of installations, practically all of them based upon the over-all estimated efficiency of the boilers. Before trial, however, it is not possible to easily calculate what efficiency can be obtained, so at best, any selection made on such a basis, is a guess.

Ques. Give an approximately correct method of selecting the proper size nozzle?

Ans. Start the burner at a firing rate of one gallon per hour for each 300 sq. ft. of steam radiation, or 480 sq. ft. of hot water radiation, applying these figures to the total load.

Example.— A burner carrying a total load of 750 sq. ft. of steam radiation, which is equivalent to 1,200 sq. ft. of hot water radiation,

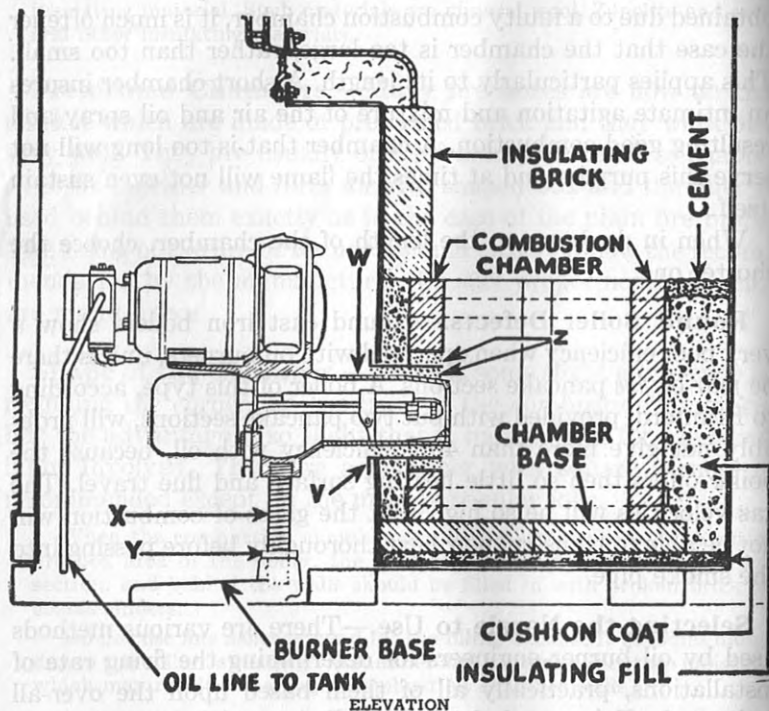
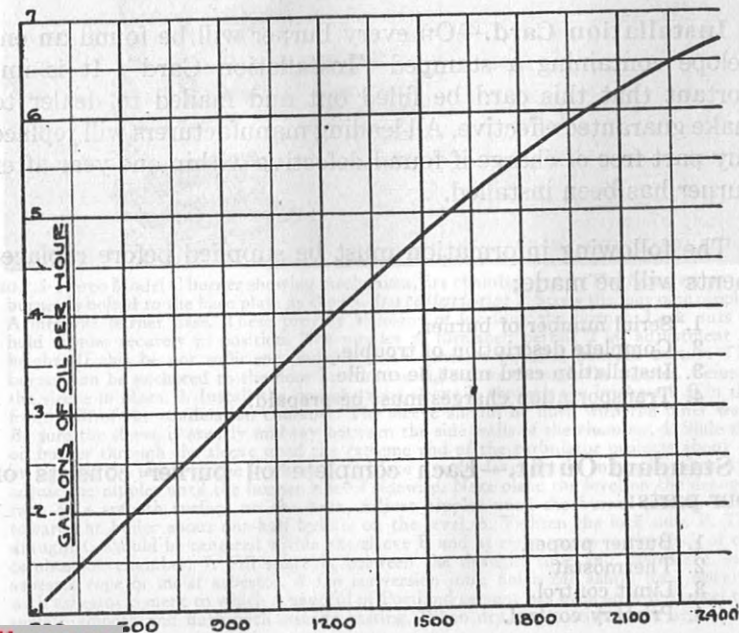
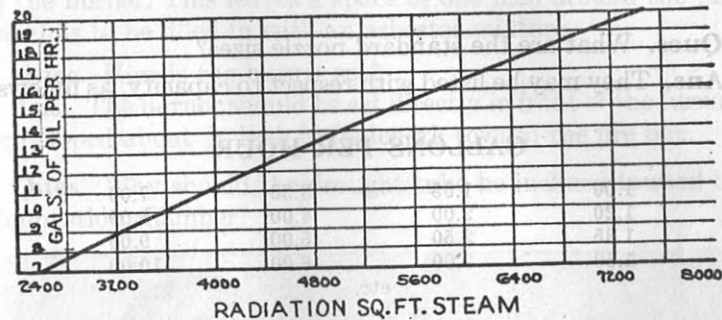

FIG. 4.—Pedestal type burner Arco M-S installed with a pre-cast chamber. **Instructions:**
 1. Regulate the burner height by loosening lock nut Y and turning adjusting nipple X to be in exact center of air tube sleeve V. Tighten lock nut Y. 2. Slide burner through opening in the pre-cast combustion chamber until end of air tube W projects about $\frac{1}{4}$ in. beyond the inside of the chamber. 3. Be sure burner is centered, not touching heater, and at right angles to the heater. 4. Seal thoroughly the space Z between air tube W and sleeve V, also between sleeve V and the chamber, with wet asbestos cement. This is done within the heater.

Curve Showing Nozzle Size

TOTAL BOILER LOAD; EFF. 60%



should be fired with a 2.5 gallon nozzle. If the first test show exceptionally fast steaming or water heating, the next smaller size nozzle can be used. On the other hand, if the heating be slow, use the next size larger nozzle.

Ques. What are the standard nozzle sizes?

Ans. They may be listed with respect to capacity, as follows:

GALLONS PER HOUR

1.00	1.65	3.50	7.00
1.20	2.00	4.00	8.00
1.35	2.50	5.00	9.00
1.50	3.00	6.00	10.00

etc.

Installation Card.—On every burner will be found an envelope containing a stamped "Installation Card". It is important that this card be filled out and mailed to dealer to make guarantee effective. All leading manufacturers will replace any part free of charge if found defective within one year after burner has been installed.

The following information must be supplied before replacements will be made:

1. Serial number of burner.
2. Complete description of trouble.
3. Installation card must be on file.
4. Transportation charges must be prepaid.

Standard Outfit.—Each complete oil burner consists of four parts:

1. Burner proper.
2. Thermostat.
3. Limit control.
4. Primary control.

Setting the Burner.—In the front wall of the combustion chamber, leave a hole 2 ins. larger in diameter than the air tube of the burner. This leaves a space of one inch around the tube which is to be filled in with an asbestos mixture.

Ques. How is the burner set?

Ans. The burner should be set directly in front of the furnace and sloped about $\frac{1}{4}$ inch in its length toward the fire box.

Ques. Why should the draught tube be inclined toward the combustion chamber?

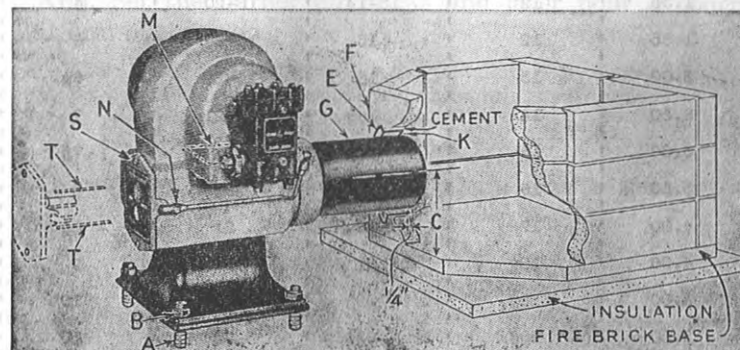

FIG. 5—Arco Model C burner showing mechanism, fire chamber, etc. 1. The flange mounted burner is bolted to the base plate as shown. **Installations:** 2. Screw the four pipe nipples B hold nipples securely in position. The nipples as furnished permit 2 in. adjustment in height. If this be not sufficient, build a small concrete pedestal beneath burner. The burner can be anchored to the floor by running lag screws through the nipples. Cement the sleeve in place. 3. Install the draught tube sleeve E through the brickwork F in the front wall of the combustion chamber. The sleeve should be flush with the inner wall. Be sure the sleeve is exactly midway between the side walls of the chamber. 4. Slide the oil burner through the sleeve until the extreme end of the turbulator projects about $\frac{1}{4}$ in. beyond the inside of the brickwork. 5. Place a small level on the motor housing, and adjust the nipples until the burner is level sidewise. Next place the level on the draught tube or a smooth surface on the base. Adjust nipples until the burner pitches down toward the boiler about one-half bubble on the level. 6. Tighten the lock nuts B. The draught G should be centered within the sleeve E and at right angles to the back of the combustion chamber. 7. Fill space K between the draught tube and the sleeve with asbestos rope or moist asbestos. 8. On conversion jobs, finish the asphalt door opening with asbestos cement to which a handful of Portland cement has been added. Trowel the surface smooth and flush with outside casting. When dry, paint with black asphaltum paint.

Ans. So that any oil that may drop from the nozzle will drain into the combustion chamber and not out on the basement floor.

Ques. How may the noise of operation be reduced?

BURNER SETTING TABLE

Gal. Oil Per Hr.	Width of Chamber	Length of Chamber	Height of Chamber	Distance of Nozzle from Chamber Floor
1.35	12	13-14	15-20	6
1.65	12	15	15-20	6
2.00	13	16	15-20	6½
2.50	14	16½	20-21	7
3.00	15	17½	21	7½
3.50	16	19	21	8
4.00	17	20	21	8½
4.50	18½	21	21	9
5.00	19½	22½	22	10
5.50	20½	23½	22	10
6.00	21½	24½	22	11
6.50	22½	26	22	11
7.00	23½	27	23	12
7.50	24½	28	23	12½
8.00	26	29½	23	13
8.50	27	30	25	13½
9.50	28	32	25	14
12.00	32	40	26	15
15.00	34-36	45	28	15
19.00	34-36	50	28	17

Ans. By setting the burner on rubber blocks.

Ques. How high should the burner be set?

Ans. The burner should be set so that the center of the nozzle is above the combustion floor a distance as recommended in the table on page 220 which gives also combustion chamber dimensions.

Ques. What should be done if there be not sufficient leg adjustment to allow full height?

Ans. Set the burner on bricks and later pour a concrete platform of the proper height.

There should be no delay in the installation in such cases if the bricks be placed under the feet and these bricks surrounded with concrete when the installation is complete.

Ques. How should the air or draught tube be pointed and why?

Ans. It should point directly at the mid point of the back wall to avoid an off sided flame and possible carbon deposits on one side.

Ques. What should be done in placing the burner?

Ans. It should be leveled.

Wiring to Burner.—All wiring should be done in accordance with the National Electric Code. Do not run conduit directly to the burner. All vibrations or noises occurring at that source will be transmitted and amplified through the conduit and into the building.

From the conduit, run at least 18 ins. of Greenfield flexible cable to the burner.

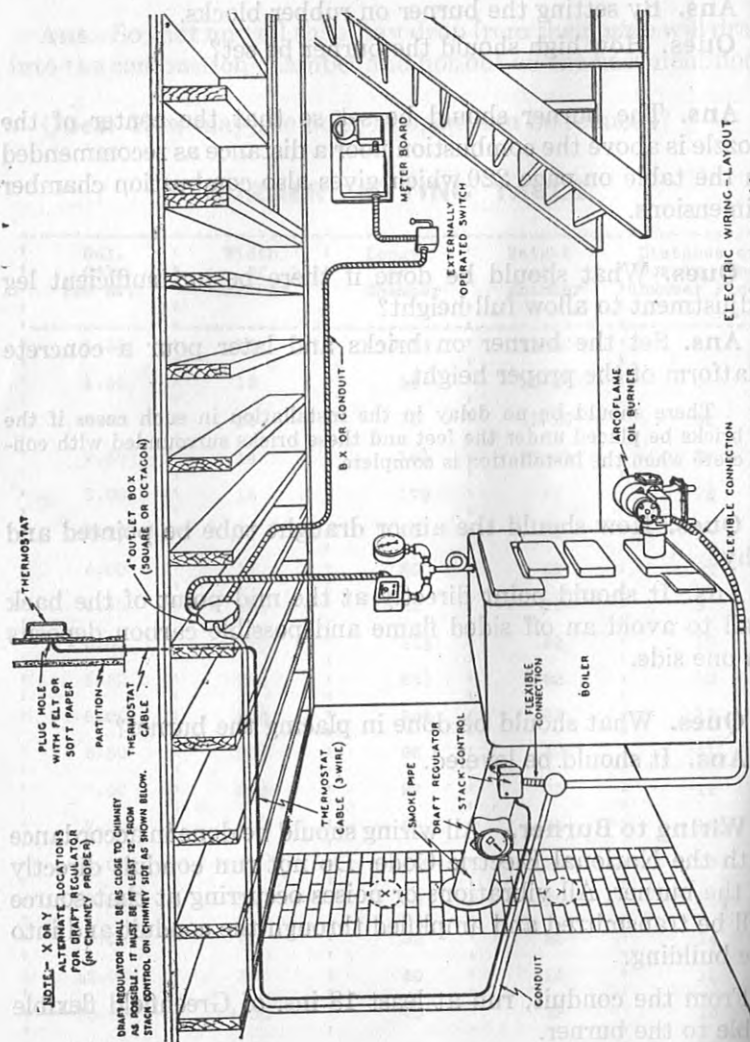

FIG. 6.—Electric wiring layout. Pictorial view of a simple hook-up which may be used as a guide.

The wiring should be done by a licensed experienced electrician following the wiring diagram for the installation being wired.

Location and Wiring of Controls.—The following instructions apply to standard controls:

Thermostat.—The thermostat should be placed in the room in which the family spends the most of its time. Select a location where it will not be subject to draughts or cold blasts of air when a door is opened, and where it will not be exposed to heat from a radiator, radio or sunlight through a window. In short, a location where it will be subject to the *average* temperature of the room.

It should be placed at a 4 foot level. Be sure also that the thermostat is attached to a solid wall, and not too near a door whose opening and closing will cause considerable vibration.

Typical wiring procedure is as follows:

1. Drill locating hole in floor at an angle toward the center of partition, directly under thermostat location. Drill hole up from basement large enough to accommodate low voltage cable.
2. Drill a hole about $\frac{1}{2}$ inch in diameter in the plaster at the level selected for the thermostat location, directly over the hole in floor.
3. Draw low voltage wiring through hole in floor up through partition and out of hole in wall in the usual manner.

For ordinary runs not exceeding 60 feet in length, use standard 3 conductor thermostat cable, obtainable at any oil burner or electrical supply house.

For runs exceeding 60 feet, use 3 wire BX, with wires not smaller than No. 14. The voltage drop in long runs is so great when small wire is used that the burner control will not operate.

The terminals on the thermostat are colored **red, white and blue**. The wires in the thermostat cable are similarly colored. Connect them according to colors, and connect the other ends to the corresponding colors on the primary control at the boiler.

Ques. How is a so-called "Chronotherm" or electric clock thermostat used?

Ans. For this type thermostat, a transformer is furnished with the instrument. This is to reduce the voltage from the main line voltage to 20 volts, which is required to operate the electric clock. It is necessary to run two more wires than is required by a plain thermostat.

The transformer should be located in the basement, in a place convenient to connect with the thermostat cable. A 5 wire thermostat cable is available for the installation of a Chronotherm. Two wires from the main supply outlet should be run to the primary of this transformer, and two wires from the secondary to the clock connections of the Chronotherm.

Boiler Control Wiring.—These controls for high voltage should be connected in series with the safety control relay on the main line. Wiring should be enclosed in BX or conduit.

Wiring to Primary Control.—Allow for a length of at least 18 in. of Greenfield flexible cable from the conduit to the relay. This will make it possible to easily remove the relay to clean the bimetallic helix, without disconnecting any of the wiring.

For Hot Water Circulating Systems.—In hot water heating systems where a circulator is used, in such systems as the Minneapolis-Honeywell, or similar system, it is necessary to use a line voltage thermostat. Specifications should so state when the burner is ordered to use with any of these systems.

In these cases, the thermostat does not control the burner operation at all, but controls only the circulator motor. The thermostat thus is a single pole switch in one leg of the circulator motor circuit. A two wire cable is used for the connection between the circulator and the thermostat.

The operation of the burner is controlled by an immersed aquastat installed in the boiler. This aquastat is connected directly with the "protecto" or safety relay.

On the Minneapolis-Honeywell immersion aquastat there are six binding posts in two groups of three each, one group marked "Relay"

and the other marked "Thermostat". The three posts marked "Relay" are red, white and blue, and should be connected to the corresponding posts on the relay.

© InspectAPedia.com

2. Adjusting.

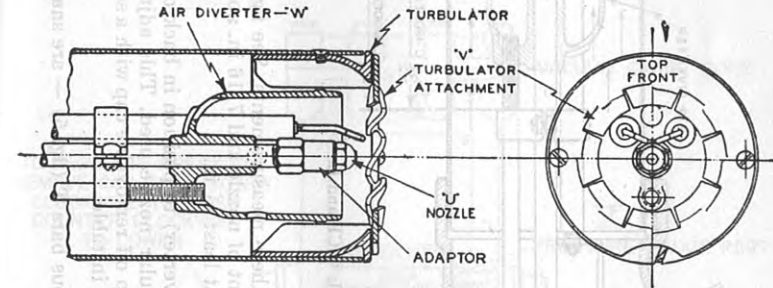

Fig. 7.—Application of Arco (Models C, CF and L) turbulator attachment; used for 1.35 gallon and smaller nozzles.

Starting the Burner.—Remove the oil tube assembly from the burner as follows: See fig. 5. Disconnect the copper tube fitting N at the rear right of the burner. Remove the two chromed screws S holding the back plate in place. Pull out assembly about 3 ins. Release ignition bus bars T, from transformer clips by pulling ends of bus bars T to the right. Withdraw the assembly. 2. Install the proper nozzle U fig. 7, required to carry the load.

Be sure to remove the strainer from the nozzle and see that swirl pin is tight. Replace strainer and screw nozzle into the brass adaptor. Make sure this is tight. For 1.25 and 1.35 gallon nozzles, be sure the turbulator attachment V is attached. See fig. 7.

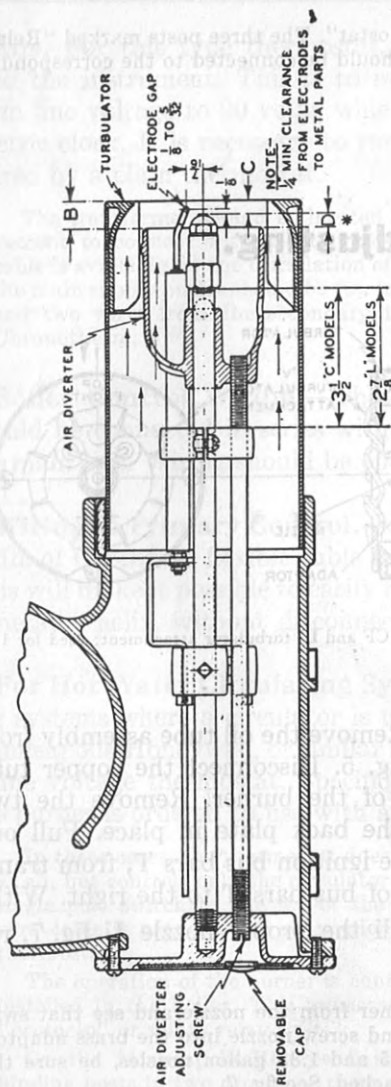

Fig. 8.—Arco air diverter and electrode setting — Models C-CF and L.

3. Check electrodes. Use a ruler to make these measurements. See fig. 8. Gap $\frac{1}{8}$ in. to $\frac{5}{32}$ in. Electrodes are set approximately $\frac{1}{8}$ in. in front of nozzle and $\frac{7}{16}$ in. above the nozzle center. Bare electrode wires shall clear all metal parts by at least $\frac{1}{4}$ in.
4. Important: Adjust the cup W (or air diverter) to position in back of nozzle tip (dimension D) given in Manufacturer's table for the particular nozzle used. This adjustment will be correct for the majority of cases. To accomplish this, snap off removable cap with a screw driver, and turn the air diverter adjusting screw to the setting shown in table.
5. Replace the oil tube assembly. Be sure bus bars T (fig. 5) — are snapped into clips.
6. Open all oil valves.

7. Open observation port or fire door of boiler or furnace.
8. See that the proper fuses are in place.

9. Purge the air from the pump assembly by removing lower plug Z on side of pump. See fig. 9. Set thermostat above room temperature. Close burner switch and run burner until oil flows from this opening. Catch this in a can or jar. When no further air is evidenced and a steady oil stream appears then:

10. Stop the burner and install a pressure gauge (0—150 or 200 pound scale).

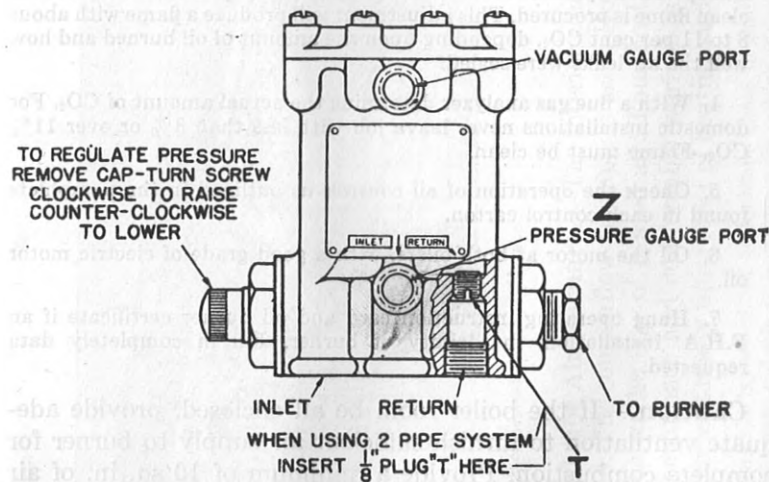

Fig. 9.—Pump assembly.

11. Start the burner and adjust the pressure regulating valve see fig. 9, to about 95 lbs. Adjust the air shutter M, fig. 5, to produce a clean flame.
12. With a lighted candle, or match, check for air leaks around base and frames of heater. If any leaks be found, seal tightly.
13. Inspect all joints and fittings for oil leaks.

Final Adjustments.—1. Important. Be sure that the flame does not lick back into the air diverter W. The base of the flame should float about two (2) inches from end of air tube. This can be seen with a flame mirror. Turning the adjusting screw fig. 8, to open, will cause the flame to float further away from the end of the air tube and vice versa.

2. Adjust the draught regulator to provide about .02 in. draught over the fire. Use a draught gauge.

3. Reset the air shutter M, fig. 5, until the flame becomes a trifle smoky. Then open the air shutter carefully to the point where a smooth clean flame is procured. This adjustment will produce a flame with about 8 to 11 per cent CO₂, depending upon the amount of oil burned and how well the air leaks were sealed.

4. With a flue gas analyzer determine the actual amount of CO₂. For domestic installations never leave job with less than 8% or over 11% CO₂. Flame must be clean.

5. Check the operation of all controls as outlined in the pamphlets found in each control carton.

6. Oil the motor at both oilers, with a good grade of electric motor oil.

7. Hang operating instruction card and oil burner certificate if an F.H.A. installation, in vicinity of burner. Fill in completely data requested.

Caution.—If the boiler room be all enclosed, provide adequate ventilation to furnish sufficient air supply to burner for complete combustion. Provide a minimum of 10 sq. in. of air opening for each gallon of oil burned per hour.

Fire Extinguisher.—If required by local ordinance, install approved type.

Follow up Service.—Inspect installation 2 or 3 weeks after placed in operation, and recheck the control system, electrodes, flame, CO₂, draught, stack temperature, as well as oil lines for leaks.

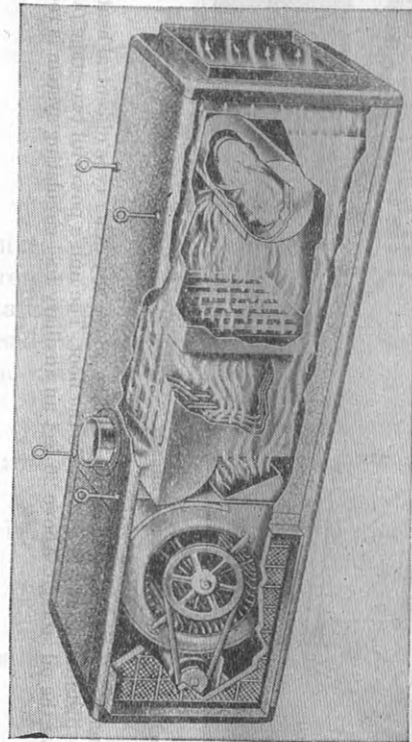

FIG. 10.—Gilbarco suspended hot air furnace.

Gilbarco Suspended Hot Air Furnace.—The interior construction and suspension eyes are shown in fig. 10. The counterflow principle is used. Hot combustion gases move in the opposite direction to the flow of heated air. Thus heat is transferred uniformly through all parts of the furnace and comfortable warmth is obtained from the fuel. Multiple vertical flues present many square feet of heating surface to the circulating air.

This air passes between thin layers of hot combustion gases in sandwich-like form. The stainless steel combustion chamber heats quickly to incandescence, which radiates heat directly to the prime heating surface of the fire box.

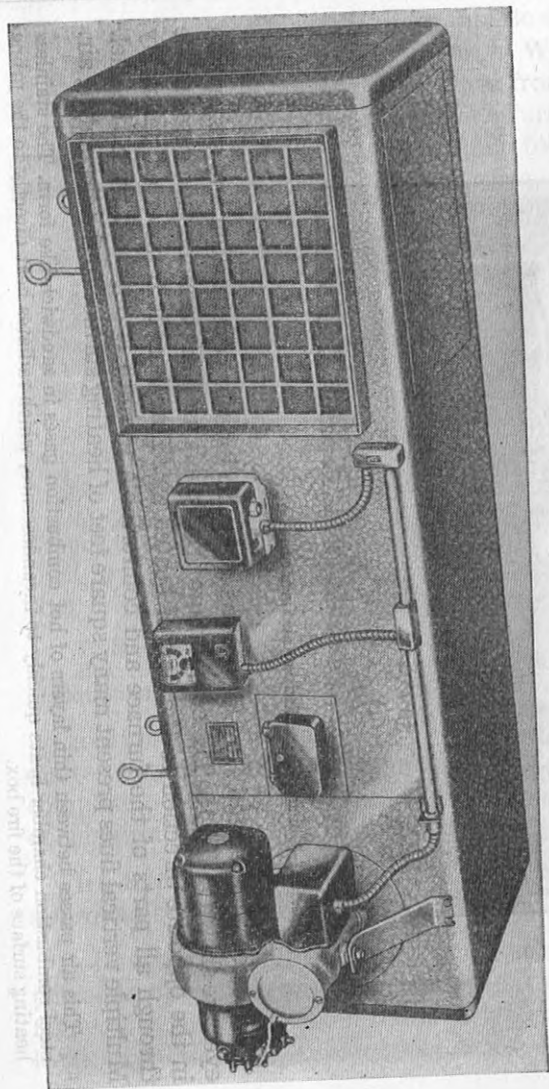

FIG. 11.—Left hand model Gilbarco suspended furnace.

These furnaces can be installed in any building where any other type of central heating can be used. They can be installed at any height above the floor. The unit's powerful two-stage pump will lift fuel 20 feet above the oil storage. Above 20 feet an auxiliary fuel circulating system is required.